

TECHNICAL DATA

Three Phase Electric Motors - Cast Iron Frame
HE30 180 M1 2 IE2
22 kW / 30 Cv
2950 RPM

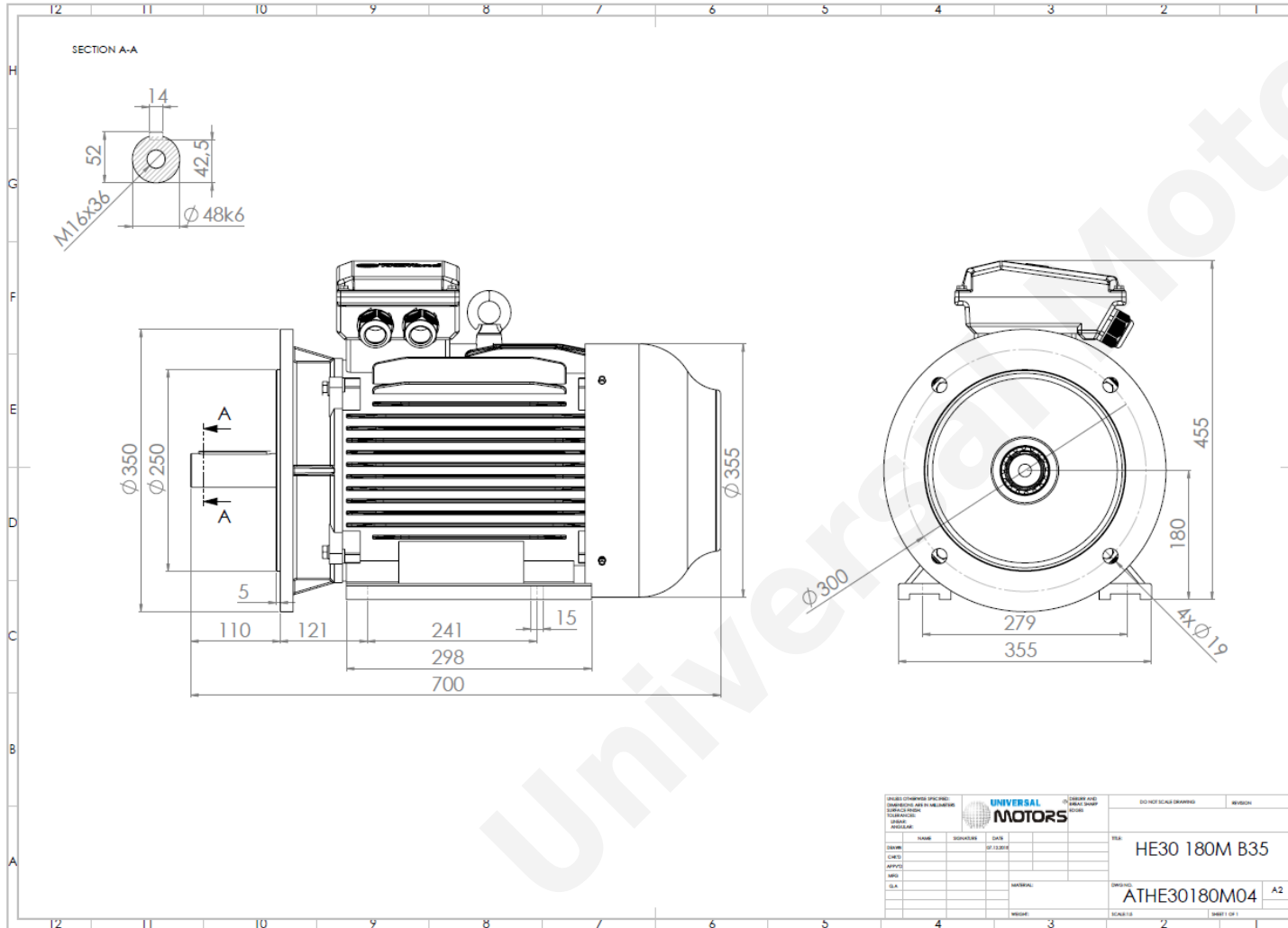

Motor type:	HE30 180 M1 2 IE2
Output:	22 kW / 30 Cv
Speed (min^{-1}):	2950 RPM
Frequency:	50 Hz
Voltage:	400 V
Current:	39.1 A
Power factor ($\text{Cos } \phi$):	0.89
Poles:	2
Insulation class:	F
Temperature rise Class:	B
Efficiency 50%:	91.1 %
Efficiency 75%:	91.8 %
Efficiency 100%:	91.3 %
Torque:	71 N.m
Tstarting/Tnominal:	2.2
Istarting/Inominal:	8.2
Tmaximum/Tnominal:	2.3
Noise:	72 Db(A)
Weight:	195 Kg
Bearing DE:	6311 C3
Bearing NDE:	6311 C3

Regime - S1

Altitude - 1000m

Environment Temperature - 40°C

CONTACTS:

UNIVERSAL MOTORS Tel: +351 252 299 080
Rua de São Brás,745 Fax: +351 252 299 089
4480-782 VILA DO CONDE Mail: geral@universalmotors.pt

* References applied only in the UK